

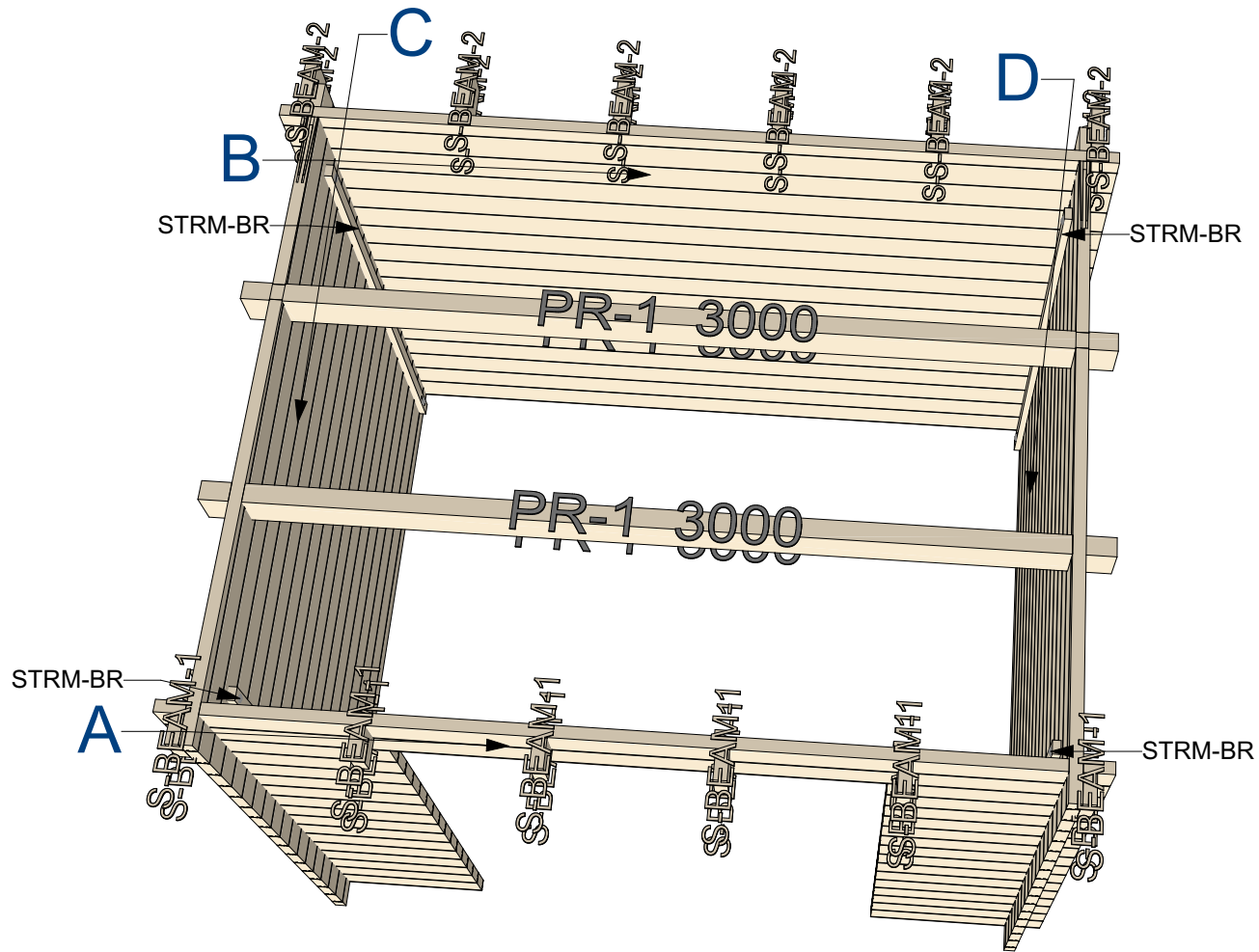

44 Eric 3x2,5 v.1

Walls and purlins positions



| | | | | |
|------------|---------------|-------------|-------|-------|
| Thickness: | Project name: | Project ID: | Year: | Page: |
| 44 | Eric 3x2,5 | v.1 | 2023 | 2 |

Floor bearers 1:50

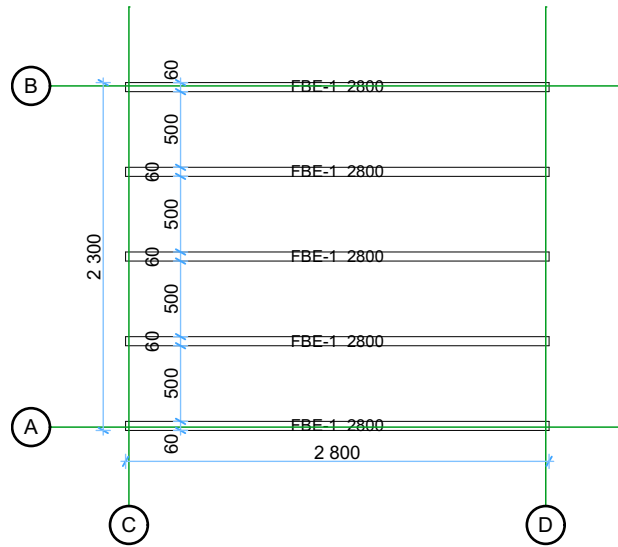

Ground floor plan 1:50

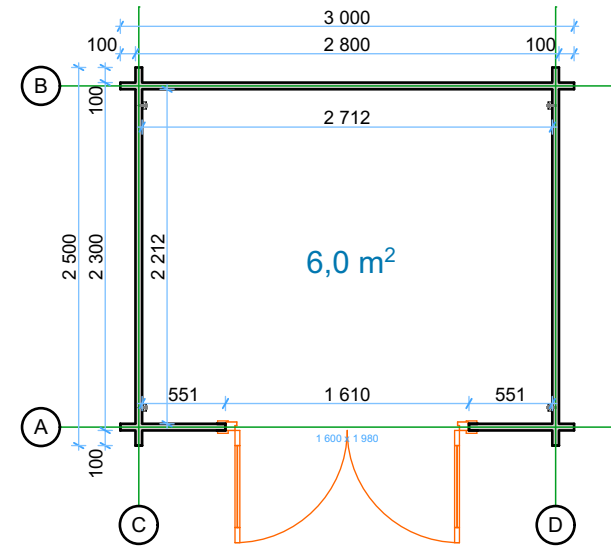

Floor boards 1:50

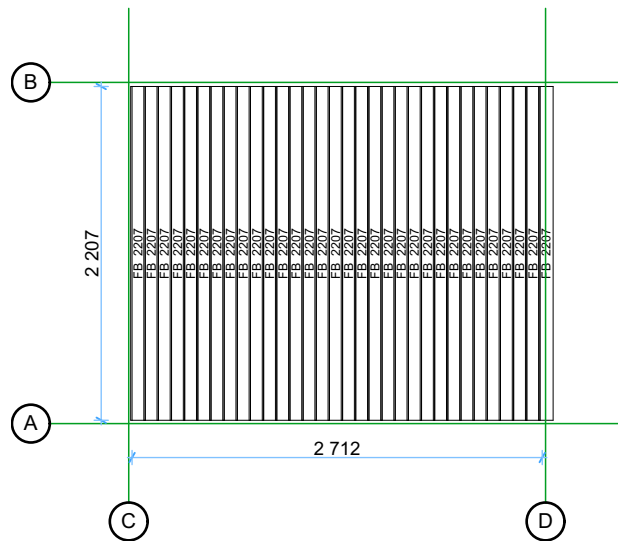

Roof boards 1:50

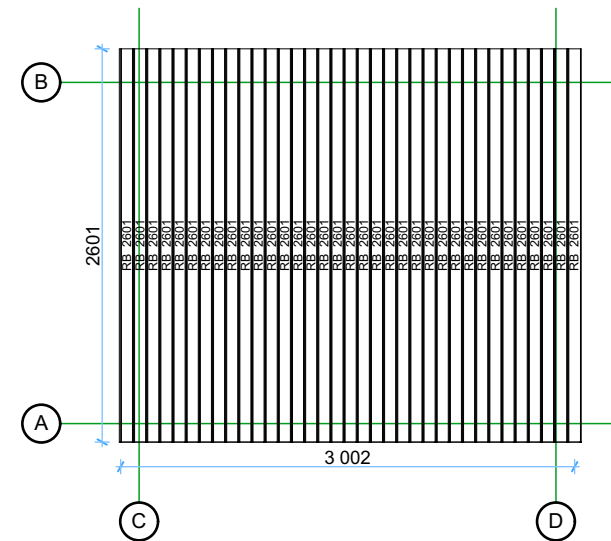

| | | | | |
|------------|---------------|-------------|-------|-------|
| Thickness: | Project name: | Project ID: | Year: | Page: |
| 44 | Eric 3x2,5 | v.1 | 2023 | 3 |

Wall A

1:50

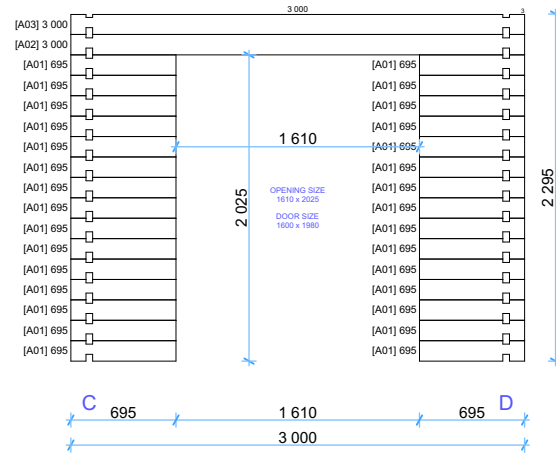

Wall C

1:50

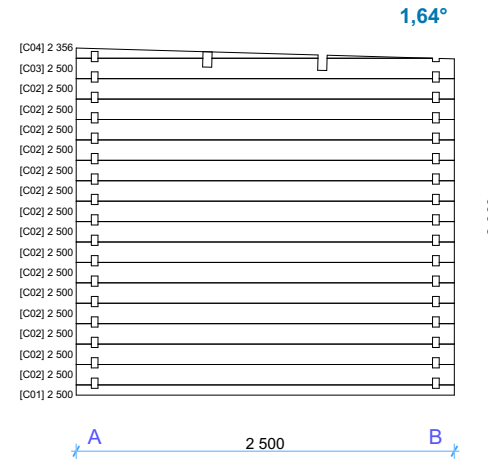

Wall B

1:50

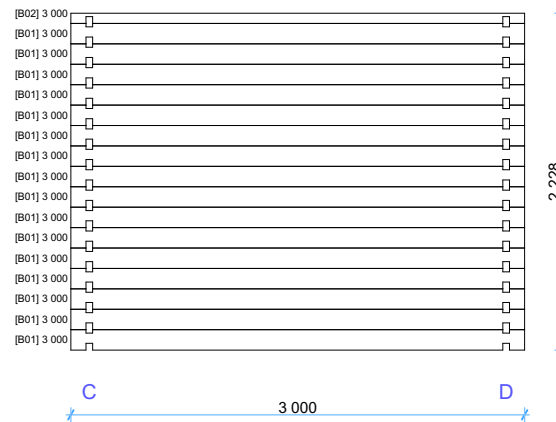

Wall D

1:50

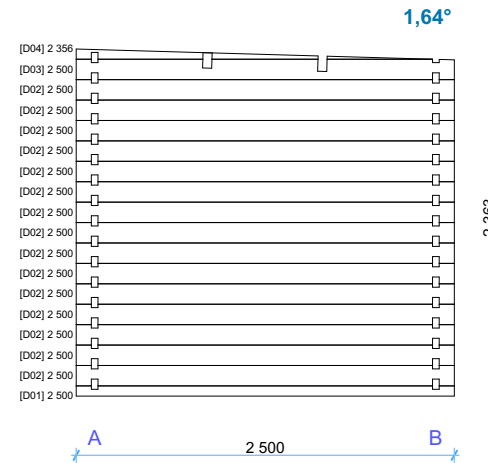

| | | | | |
|------------|---------------|-------------|-------|-------|
| Thickness: | Project name: | Project ID: | Year: | Page: |
| 44 | Eric 3x2,5 | v.1 | 2023 | 4 |

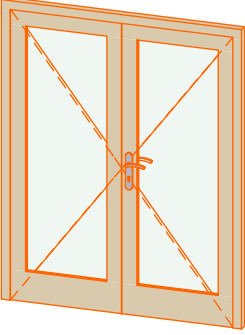
| 44 Eric 3x2,5 no canopy v.1 windows and doors list | | | | | | | |
|--|----------------|----------------|-------------|-------------|---------------------|----------|---|
| Barcode | Type-quality | Wall Thickness | W x H Size | Orientation | Glazing | Quantity | 3D Axonometry |
| PP198160-3 | Door - Premium | 44 | 1 600×1 980 | R | 100%, double glazed | 1 |  |

| | | | | |
|------------|---------------|-------------|-------|-------|
| Thickness: | Project name: | Project ID: | Year: | Page: |
| 44 | Eric 3x2,5 | v.1 | 2023 | 5 |